

# Installation Procedure

## **Canon BW Expansion Bus-D1**

**Canon**



## Application

This manual has been issued by Canon Inc. for qualified persons to learn technical theory, installation, maintenance, and repair of products. This manual covers all localities where the products are sold. For this reason, there may be information in this manual that does not apply to your locality.

## Corrections

This manual may contain technical inaccuracies or typographical errors due to improvements or changes in products. When changes occur in applicable products or in the contents of this manual, Canon will release technical information as the need arises. In the event of major changes in the contents of this manual over a long or short period, Canon will issue a new edition of this manual.

The following paragraph does not apply to any countries where such provisions are inconsistent with local law.

## Trademarks

The product names and company names used in this manual are the registered trademarks of the individual companies.

## Copyright

This manual is copyrighted with all rights reserved. Under the copyright laws, this manual may not be copied, reproduced or translated into another language, in whole or in part, without the written consent of Canon Inc.

***COPYRIGHT © 2001 CANON INC.***

*Printed in Japan*

## Caution









Use of this manual should be strictly supervised to avoid disclosure of confidential information.

---



## Symbols Used

---

This documentation uses the following symbols to indicate special information:

Symbol	Description
	Indicates an item of a non-specific nature, possibly classified as Note, Caution, or Warning.
	Indicates an item requiring care to avoid electric shocks.
	Indicates an item requiring care to avoid combustion (fire).
	Indicates an item prohibiting disassembly to avoid electric shocks or problems.
	Indicates an item requiring disconnection of the power plug from the electric outlet.
 Memo	Indicates an item intended to provide notes assisting the understanding of the topic in question.
 REF.	Indicates an item of reference assisting the understanding of the topic in question.
	Provides a description of a service mode.
	Provides a description of the nature of an error indication.

The following rules apply throughout this Service Manual:

1. Each chapter contains sections explaining the purpose of specific functions and the relationship between electrical and mechanical systems with reference to the timing of operation. In the diagrams,  represents the path of mechanical drive; where a signal name accompanies the symbol, the arrow  indicates the direction of the electric signal. The expression "turn on the power" means flipping on the power switch, closing the front door, and closing the delivery unit door, which results in supplying the machine with power.
2. In the digital circuits, '1' is used to indicate that the voltage level of a given signal is "High", while '0' is used to indicate "Low". (The voltage value, however, differs from circuit to circuit.) In addition, the asterisk (\*) as in "DRMD\*" indicates that the DRMD signal goes on when '0'.

In practically all cases, the internal mechanisms of a microprocessor cannot be checked in the field. Therefore, the operations of the microprocessors used in the machines are not discussed: they are explained in terms of from sensors to the input of the DC controller PCB and from the output of the DC controller PCB to the loads.

The descriptions in this Service Manual are subject to change without notice for product improvement or other purposes, and major changes will be communicated in the form of Service Information bulletins.

All service persons are expected to have a good understanding of the contents of this Service Manual and all relevant Service Information bulletins and be able to identify and isolate faults in the machine."



# Contents

## Chapter 1 Installation Procedure

1.1 Checking components .....	2
1.1.1 Checking accessories .....	2
1.2 Installation procedure.....	3
1.2.1 Installation procedure.....	3





---

# Chapter 1 Installation Procedure

---

---

# 1.1 Checking components

---

## 1.1.1 Checking accessories

0011-3999

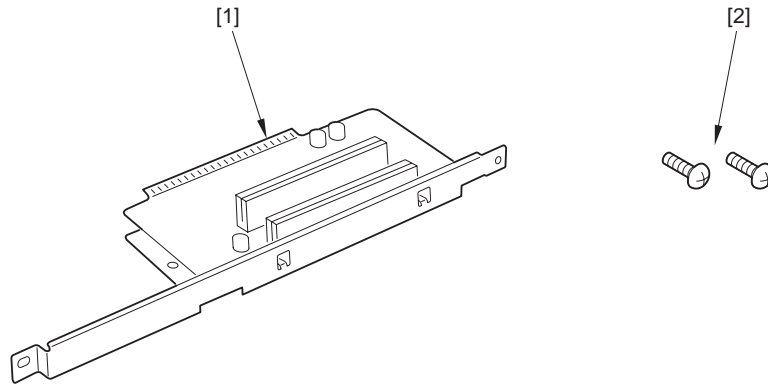

F-1-1

[1]	Expansion Bus	1pc
[2]	Screw (Bind; M3X6)	2pcs

## 1.2 Installation procedure

### 1.2.1 Installation procedure

0011-4046

#### 1. Turning Off the Host Machine

**⚠** How to turn off the main power:

When turning off the main power, follow the procedure below in order to protect the hard disk of the machine.

1. Press the power switch on the control panel for 3 sec or more.
2. Operate the touch panel following the instruction display for the shut down sequence so that the main power can be ready for turning off.
3. Turn off the main power.
4. Unplug the power cable (for outlet) from the wall outlet.

#### 2. Installation procedure

- 1) Detach the main controller cover [1].  
- Screw [2] X 10pcs

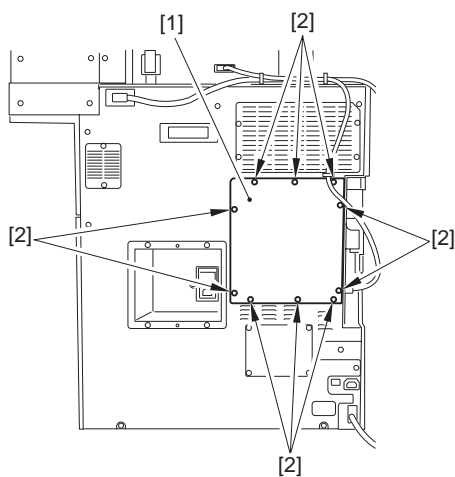

F-1-2

- 2) Detach the rear cover [1].  
- Reader power cable [2] X 1pc  
- Wire saddle [3] X 1pc  
- Screw [4] X 8pcs

(In printer model unscrew 8 screws only)

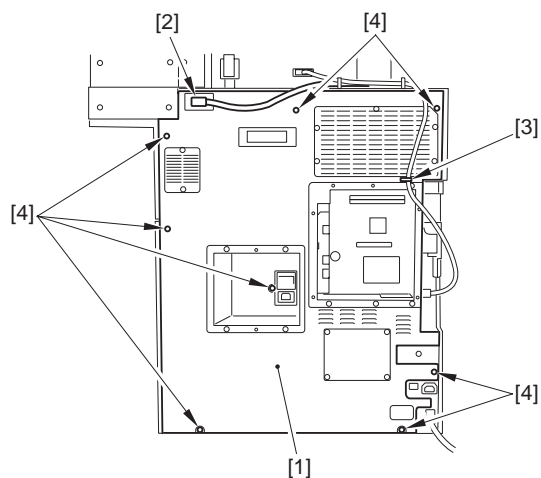

F-1-3

- 3) Mount the Expansion Bus [1].  
- Screw (Bind; M3X6) X 2pcs



Be sure to work holding the frame of Expansion Bus.

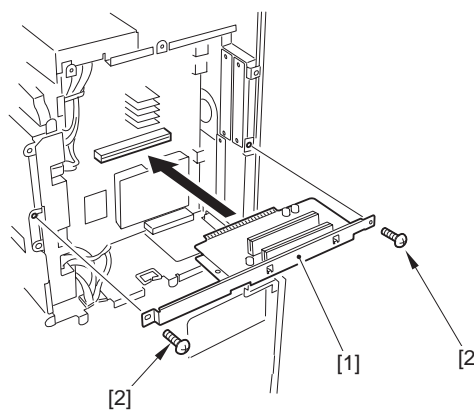

F-1-4

- 4) Mount the following removed parts.  
- Rear cover  
- Reader power cable (Copy model only)  
- Main controller cover
- 5) Plug the power cable of host machine into the wall outlet.

6) Turn on the main power switch.

Feb 7 2006

**Canon**